

MONOLITHIC BIPOLAR INTEGRATED CIRCUIT  
VOLTAGE STABILIZER FOR ELECTRONIC TUNER

The  $\mu$ PC574 is a monolithic integrated voltage stabilizer especially designed as voltage supplier for electronic tuners.

FEATURES

- Low temperature coefficient
- Low dynamic resistance
- Typical reference voltage of 33 V

EQUIVALENT CIRCUIT

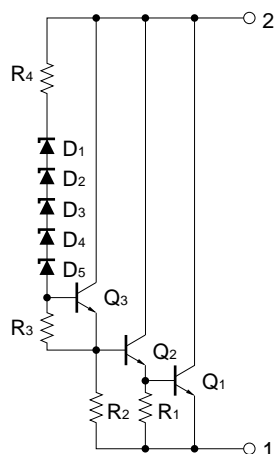

PIN CONFIGURATION (Marking Side)

$\mu$ PC574J: 2-pin plastic SIP (TO-92)

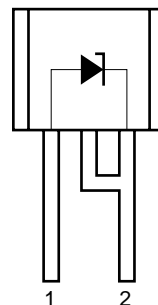

1. Anode
2. Cathode

★ ORDERING INFORMATION

Part Number	Package
$\mu$ PC574J	2-pin plastic SIP (TO-92)

The information in this document is subject to change without notice.

**ABSOLUTE MAXIMUM RATINGS (T<sub>A</sub> = 25°C, unless otherwise specified.)**

Parameter	Symbol	Ratings	Unit
Zener Current	I <sub>z</sub>	10	mA
Power Dissipation	P <sub>D</sub>	200 (T <sub>A</sub> = 75°C)	mW
Operating Ambient Temperature Range	T <sub>A</sub>	-20 to +75	°C
Storage Temperature Range	T <sub>stg</sub>	-40 to +125	°C

**Caution** Exposure to Absolute Maximum Ratings for extended periods may affect device reliability; exceeding the ratings could cause permanent damage. The parameters apply independently. The device should be operated within the limits specified under DC and AC Characteristics.

**ELECTRICAL CHARACTERISTICS (T<sub>A</sub> = 25°C, unless otherwise specified.)**

Parameter	Symbol	Conditions	MIN.	TYP.	MAX.	Unit
Stabilized Voltage	V <sub>z</sub>	I <sub>z</sub> = 5 mA	31		35	V
Stabilized Voltage Temperature Drift	ΔV <sub>z</sub> /ΔT	I <sub>z</sub> = 5 mA, T <sub>A</sub> = -20 to +75°C	-1.0	0	+1.0	mV/°C
Dynamic Resistance	r <sub>z</sub>	I <sub>z</sub> = 5 mA, f = 1 kHz, I <sub>AC</sub> = 0.5 mA		10	25	Ω

TYPICAL CHARACTERISTIC (T<sub>A</sub> = 25°C, unless otherwise specified.)

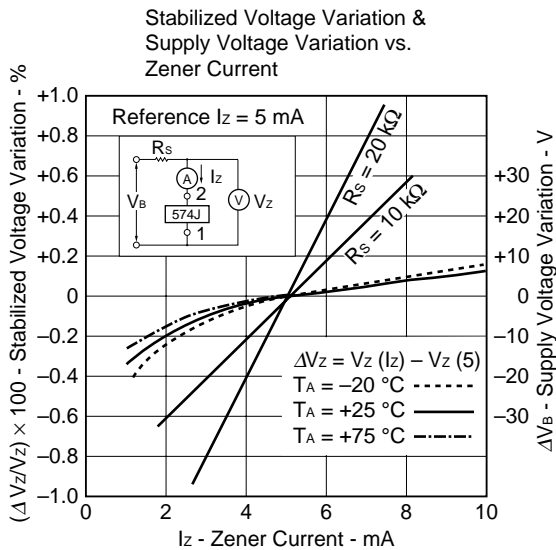
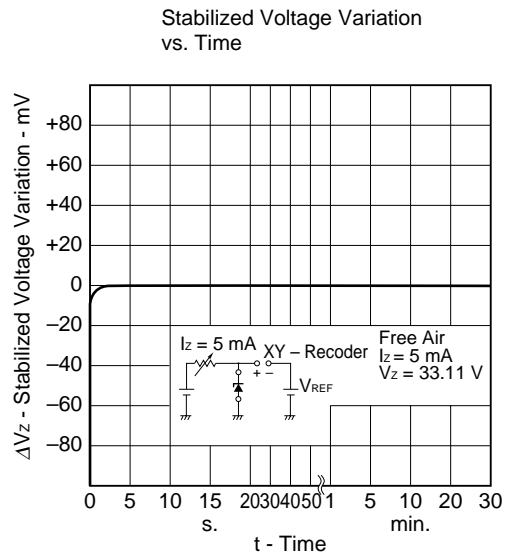
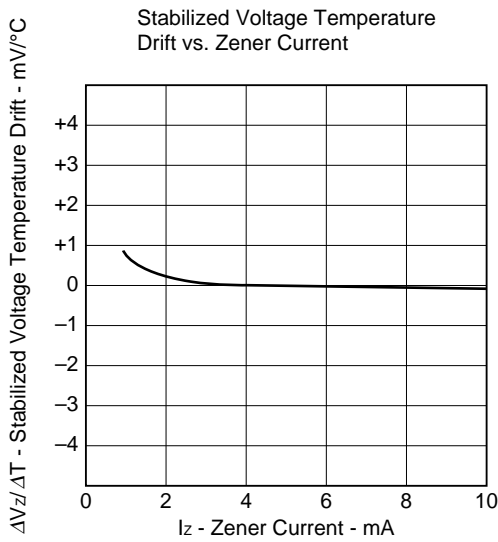
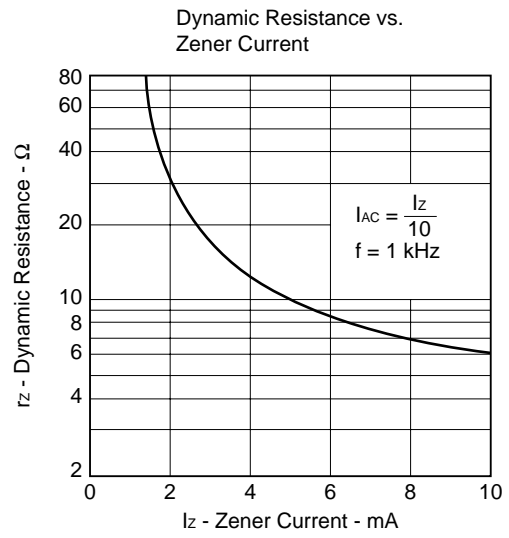
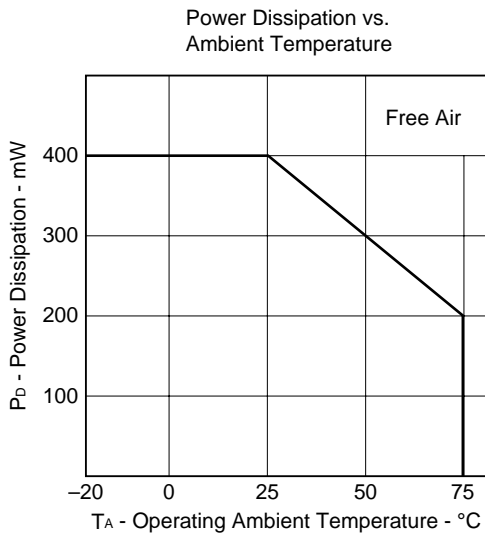

MEASURING CIRCUITS

(i) Measuring Circuit for Stabilized Voltage  $V_z$

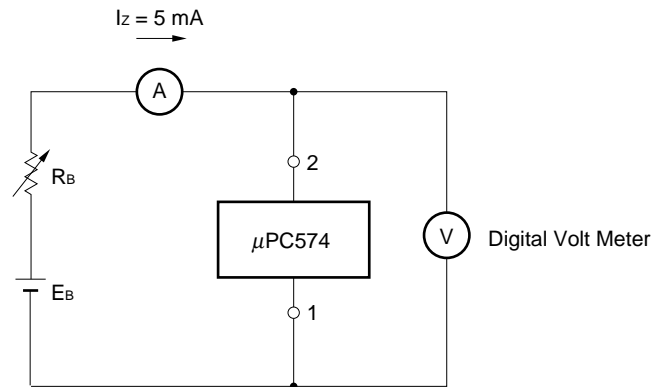

(ii) Measuring Circuit for Dynamic Resistance  $r_z$

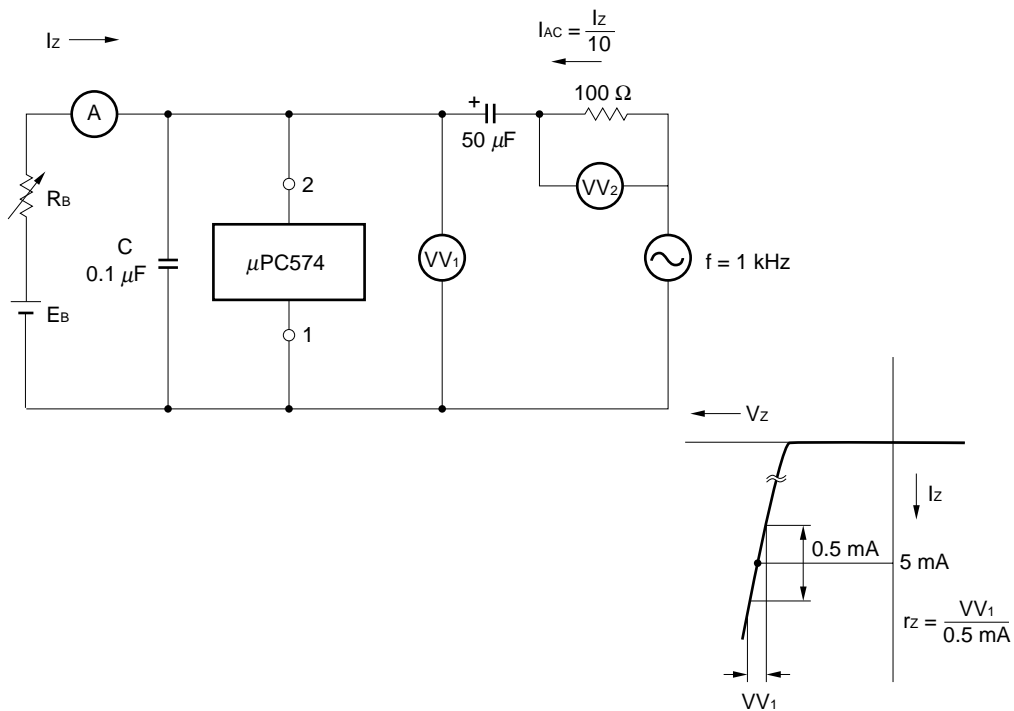

TYPICAL APPLICATION

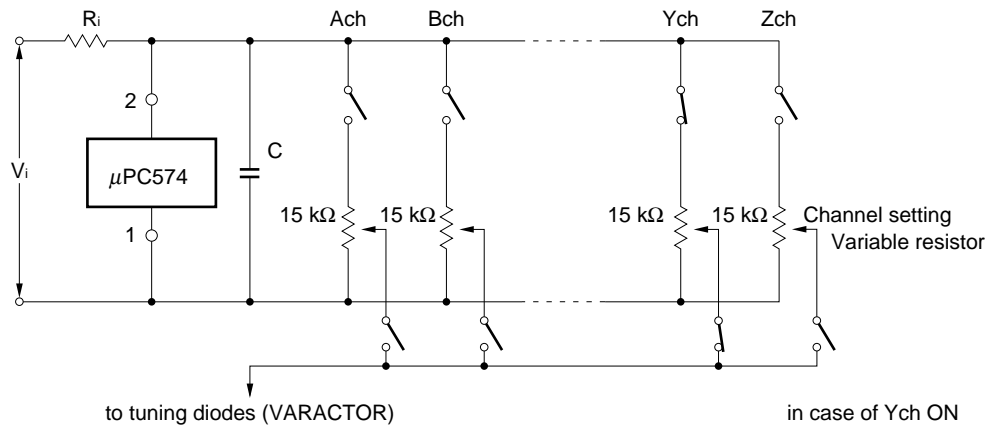

★ PACKAGE DRAWING

2 PIN PLASTIC SIP (TO-92)

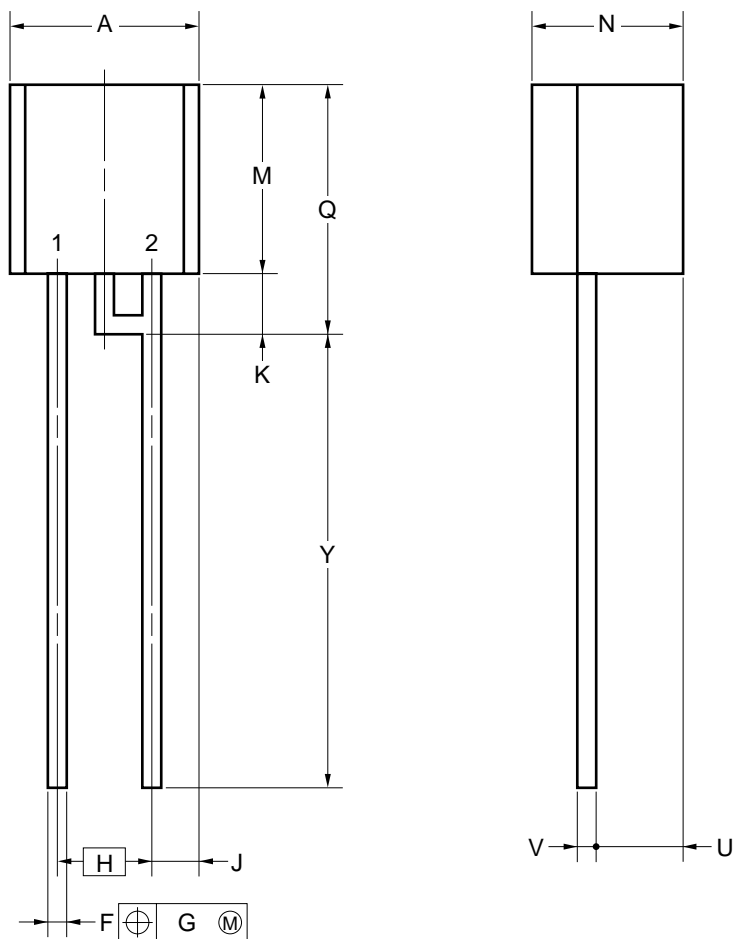

**NOTE**

Each lead centerline is located within 0.25 mm (0.01 inch) of its true position (T.P.) at maximum material condition.

ITEM	MILLIMETERS	INCHES
A	5.2 MAX.	0.205 MAX.
F	0.5±0.1	0.02 <sup>+0.004</sup> <sub>-0.005</sub>
G	0.25	0.01
H	2.54	0.1
J	1.33 MAX.	0.053 MAX.
K	1.8 MIN.	0.07 MIN.
M	5.5 MAX.	0.217 MAX.
N	4.2 MAX.	0.166 MAX.
Q	8.0 MAX.	0.315 MAX.
U	2.8 MAX.	0.111 MAX.
V	0.5±0.1	0.02 <sup>+0.004</sup> <sub>-0.005</sub>
Y	15.0±0.7	0.591 <sup>+0.028</sup> <sub>-0.029</sub>

P2J-254B-1

★ **RECOMMENDED SOLDERING CONDITIONS**

When soldering this product, it is highly recommended to observe the conditions as shown below. If other soldering processes are used, or if the soldering is performed under different conditions, please make sure to consult with our sales offices.

For more details, refer to our document “**SEMICONDUCTOR DEVICE MOUNTING TECHNOLOGY MANUAL**” (C10535E).

**Through-hole device**

**μPC574J: 2-pin plastic SIP (TO-92)**

Process	Conditions
Wave soldering (only to leads)	Solder temperature: 260°C or below, Flow time: 10 seconds or less.
Partial heating method	Pin temperature: 300°C or below, Heat time: 3 seconds or less (per each lead.)

**Caution** For through-hole device, the wave soldering process must be applied only to leads, and make sure that the package body does not get jet soldered.

## [MEMO]

The application circuits and their parameters are for reference only and are not intended for use in actual design-ins.

No part of this document may be copied or reproduced in any form or by any means without the prior written consent of NEC Corporation. NEC Corporation assumes no responsibility for any errors which may appear in this document.

NEC Corporation does not assume any liability for infringement of patents, copyrights or other intellectual property rights of third parties by or arising from use of a device described herein or any other liability arising from use of such device. No license, either express, implied or otherwise, is granted under any patents, copyrights or other intellectual property rights of NEC Corporation or others.

While NEC Corporation has been making continuous effort to enhance the reliability of its semiconductor devices, the possibility of defects cannot be eliminated entirely. To minimize risks of damage or injury to persons or property arising from a defect in an NEC semiconductor device, customers must incorporate sufficient safety measures in its design, such as redundancy, fire-containment, and anti-failure features.

NEC devices are classified into the following three quality grades:

"Standard", "Special", and "Specific". The Specific quality grade applies only to devices developed based on a customer designated "quality assurance program" for a specific application. The recommended applications of a device depend on its quality grade, as indicated below. Customers must check the quality grade of each device before using it in a particular application.

Standard: Computers, office equipment, communications equipment, test and measurement equipment, audio and visual equipment, home electronic appliances, machine tools, personal electronic equipment and industrial robots

Special: Transportation equipment (automobiles, trains, ships, etc.), traffic control systems, anti-disaster systems, anti-crime systems, safety equipment and medical equipment (not specifically designed for life support)

Specific: Aircrafts, aerospace equipment, submersible repeaters, nuclear reactor control systems, life support systems or medical equipment for life support, etc.

The quality grade of NEC devices is "Standard" unless otherwise specified in NEC's Data Sheets or Data Books. If customers intend to use NEC devices for applications other than those specified for Standard quality grade, they should contact an NEC sales representative in advance.

Anti-radioactive design is not implemented in this product.