

## DM74S240, DM74S241, DM74S244 Octal TRI-STATE® Buffer/Line Driver/Line Receiver

### General Description

These buffers/line drivers are designed to improve both the performance and PC board density of TRI-STATE buffers/drivers employed as memory-address drivers, clock drivers, and bus-oriented transmitters/receivers. Featuring 400 mV of hysteresis at each low current PNP data line input, they provide improved noise rejection and high fanout outputs, and can be used to drive terminated lines down to 133Ω.

### Features

- TRI-STATE outputs drive bus lines directly
- PNP inputs reduce DC loading on bus lines
- Hysteresis at data inputs improves noise margins

- Typical  $I_{OL}$  (sink current)  
74S 64 mA
- Typical  $I_{OH}$  (source current)  
74S -15 mA
- Typical propagation delay times  
Inverting 4.5 ns  
Noninverting 6 ns
- Typical enable/disable times 9 ns
- Typical power dissipation (enabled)  
Inverting 450 mW  
Noninverting 538 mW

### Connection Diagrams

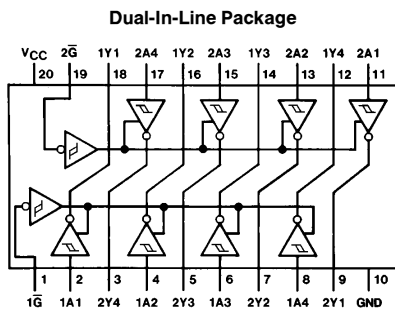

TL/F/6478-1

**Order Number DM74S240N**  
See NS Package Number N20A

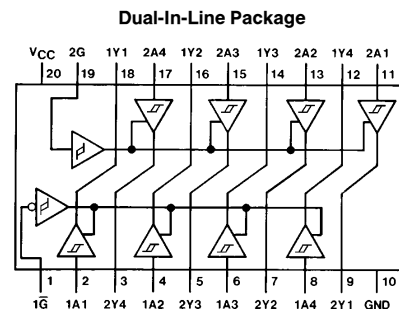

TL/F/6478-2

**Order Number DM74S241N**  
See NS Package Number N20A

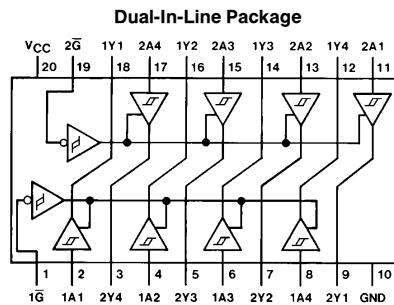

TL/F/6478-3

**Order Number DM74S244N**  
See NS Package Number N20A

TRI-STATE® is a registered trademark of National Semiconductor Corporation.

## Absolute Maximum Ratings (Note)

Supply Voltage	7V
Input Voltage	5.5V
Operating Free Air Temperature Range DM74S	0°C to +70°C
Storage Temperature Range	-65°C to +150°C

Note: The "Absolute Maximum Ratings" are those values beyond which the safety of the device cannot be guaranteed. The device should not be operated at these limits. The parametric values defined in the "Electrical Characteristics" table are not guaranteed at the absolute maximum ratings. The "Recommended Operating Conditions" table will define the conditions for actual device operation.

## Recommended Operating Conditions

Symbol	Parameter	Min	Typ	Max	Units
V <sub>CC</sub>	Supply Voltage	4.75	5	5.25	V
V <sub>IH</sub>	High Level Input Voltage	2			V
V <sub>IL</sub>	Low Level Input Voltage			0.8	V
I <sub>OH</sub>	High Level Output Current			-15	mA
I <sub>OL</sub>	Low Level Output Current			64	mA
T <sub>A</sub>	Free Air Operating Temperature	0		70	°C

## Electrical Characteristics over recommended operating free-air temperature range (unless otherwise noted)

Symbol	Parameter	Conditions	Min	Typ (Note 1)	Max	Units	
V <sub>I</sub>	Input Clamp Voltage	V <sub>CC</sub> = Min, I <sub>I</sub> = -18 mA			-1.2	V	
H <sub>ys</sub>	Hysteresis (V <sub>T+</sub> - V <sub>T-</sub> ) (Data Inputs Only)	V <sub>CC</sub> = Min	0.2	0.4		V	
V <sub>OH</sub>	High Level Output Voltage	V <sub>CC</sub> = 4.75V, V <sub>IH</sub> = 2V V <sub>IL</sub> = 0.8V, I <sub>OH</sub> = -1 mA	2.7			V	
		V <sub>CC</sub> = Min, V <sub>IH</sub> = 2V V <sub>IL</sub> = 0.8V, I <sub>OH</sub> = -3 mA	2.4	3.4			
		V <sub>CC</sub> = Min, V <sub>IH</sub> = 2V V <sub>IL</sub> = 0.5V, I <sub>OH</sub> = Max	2				
V <sub>OL</sub>	Low Level Output Voltage	V <sub>CC</sub> = Min I <sub>OL</sub> = Max V <sub>IL</sub> = 0.8V, V <sub>IH</sub> = 2V			0.55	V	
I <sub>OZH</sub>	Off-State Output Current, High Level Voltage Applied	V <sub>CC</sub> = Max V <sub>IL</sub> = 0.8V V <sub>IH</sub> = 2V			50	μA	
I <sub>OZL</sub>	Off-State Output Current, Low Level Voltage Applied				-50	μA	
I <sub>I</sub>	Input Current at Maximum Input Voltage	V <sub>CC</sub> = Max V <sub>I</sub> = 5.5V			1	mA	
I <sub>IH</sub>	High Level Input Current	V <sub>CC</sub> = Max V <sub>I</sub> = 2.7V			50	μA	
I <sub>IL</sub>	Low Level Input Current	V <sub>CC</sub> = Max V <sub>I</sub> = 0.5V	Any A			-400	μA
			Any G			-2	mA

## Electrical Characteristics

over recommended operating free-air temperature range (unless otherwise noted) (Continued)

Symbol	Parameter	Conditions	Min	Typ (Note 1)	Max	Units
$I_{OS}$	Short Circuit Output Current	$V_{CC} = \text{Max (Note 2)}$	-50		-225	mA
$I_{CC}$	Supply Current	Outputs High	S240	80	135	mA
			S241, 244	95	160	
		Outputs Low	S240	100	150	
			S241, 244	120	180	
		Outputs Disabled	S240	100	150	
			S241, 244	120	180	

**Note 1:** All typical values are at  $V_{CC} = 5V$ ,  $T_A = 25^\circ\text{C}$ .

**Note 2:** Not more than one output should be shorted at a time and duration should not exceed one second.

## Switching Characteristics:

Symbol	Parameter	Conditions	Min	Max	Units
$t_{PLH}$	Propagation Delay Time Low to High Level Output	$C_L = 45\text{ pF}$ $R_L = 90\Omega$ S240	2	7	ns
		S241, 244	2	9	
$t_{PHL}$	Propagation Delay Time High to Low Level Output	$C_L = 45\text{ pF}$ $R_L = 90\Omega$ S240	2	7	ns
		S241, 244	2	9	
$t_{PZL}$	Output Enable Time to Low Level	$C_L = 45\text{ pF}$ $R_L = 90\Omega$ S240	3	15	ns
		S241, 244	3	15	
$t_{PZH}$	Output Enable Time to High Level	$C_L = 45\text{ pF}$ $R_L = 90\Omega$ S240	2	10	ns
		S241, 244	3	12	
$t_{PLZ}$	Output Disable Time from Low Level	$C_L = 5\text{ pF}$ $R_L = 90\Omega$ S240	4	15	ns
		S241, 244	2	15	
$t_{PHZ}$	Output Disable Time from High Level	$C_L = 5\text{ pF}$ $R_L = 90\Omega$ S240	2	9	ns
		S241, 244	2	9	
$t_{PLH}$	Propagation Delay Time Low to High Level Output	$C_L = 150\text{ pF}$ $R_L = 90\Omega$ S240	3	10	ns
		S241, 244	4	12	
$t_{PHL}$	Propagation Delay Time High to Low Level Output	$C_L = 150\text{ pF}$ $R_L = 90\Omega$ S240	3	10	ns
		S241, 244	4	12	
$t_{PZL}$	Output Enable Time to Low Level	$C_L = 150\text{ pF}$ $R_L = 90\Omega$ S240	6	21	ns
		S241, 244	6	21	
$t_{PZH}$	Output Enable Time to High Level	$C_L = 150\text{ pF}$ $R_L = 90\Omega$ S240	4	12	ns
		S241, 244	4	15	

**Physical Dimensions** inches (millimeters)

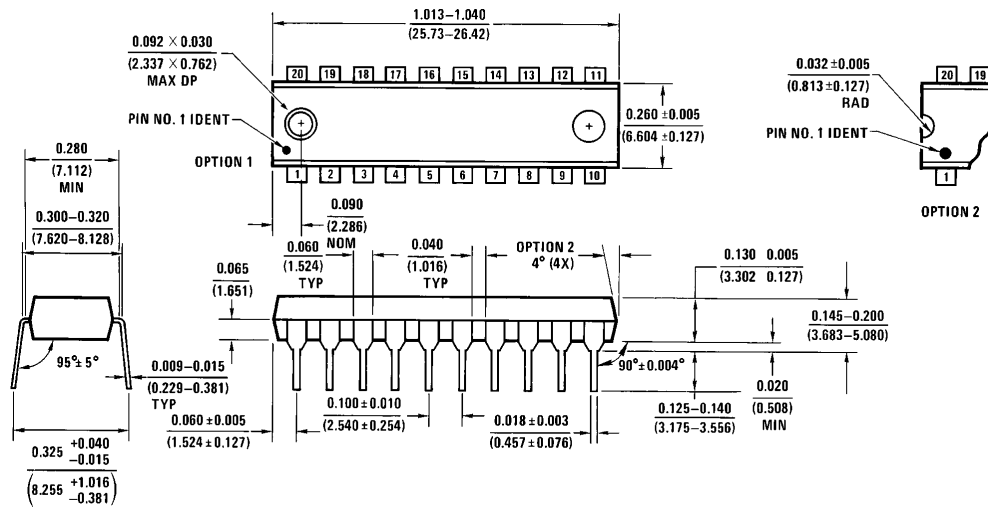

**20-Lead Molded Dual-In-Line Package (N)**  
**Order Numbers DM74S240N, DM74S241N or DM74S244N**  
**NS Package Number N20A**

N20A (REV G)

**LIFE SUPPORT POLICY**

NATIONAL'S PRODUCTS ARE NOT AUTHORIZED FOR USE AS CRITICAL COMPONENTS IN LIFE SUPPORT DEVICES OR SYSTEMS WITHOUT THE EXPRESS WRITTEN APPROVAL OF THE PRESIDENT OF NATIONAL SEMICONDUCTOR CORPORATION. As used herein:

1. Life support devices or systems are devices or systems which, (a) are intended for surgical implant into the body, or (b) support or sustain life, and whose failure to perform, when properly used in accordance with instructions for use provided in the labeling, can be reasonably expected to result in a significant injury to the user.
2. A critical component is any component of a life support device or system whose failure to perform can be reasonably expected to cause the failure of the life support device or system, or to affect its safety or effectiveness.



**National Semiconductor Corporation**  
 1111 West Bardin Road  
 Arlington, TX 76017  
 Tel: (800) 272-9959  
 Fax: (800) 737-7018

**National Semiconductor Europe**  
 Fax: (+49) 0-180-530 85 86  
 Email: cnjwge@tevm2.nsc.com  
 Deutsch Tel: (+49) 0-180-530 85 85  
 English Tel: (+49) 0-180-532 78 32  
 Français Tel: (+49) 0-180-532 93 58  
 Italiano Tel: (+49) 0-180-534 16 80

**National Semiconductor Hong Kong Ltd.**  
 19th Floor, Straight Block,  
 Ocean Centre, 5 Canton Rd.  
 Tsimshatsui, Kowloon  
 Hong Kong  
 Tel: (852) 2737-1600  
 Fax: (852) 2736-9960

**National Semiconductor Japan Ltd.**  
 Tel: 81-043-299-2309  
 Fax: 81-043-299-2408

National does not assume any responsibility for use of any circuitry described, no circuit patent licenses are implied and National reserves the right at any time without notice to change said circuitry and specifications.

This datasheet has been download from:

[www.datasheetcatalog.com](http://www.datasheetcatalog.com)

Datasheets for electronics components.